



308K OFCERT License No.: 0400040014
 300K OFCERT License No.: 0400040013

from **AGA**



Users Instructions for Rayburn 300K and Rayburn 308K Oil-Fired Cooker

Consumer Protection Act 1987

As responsible manufacturers we take care to make sure that our products are designed and constructed to meet the required safety standards when properly installed and used.

IMPORTANT NOTICE: PLEASE READ THE ACCOMPANYING WARRANTY.

Any alteration that is not approved by Aga could invalidate the approval of the appliance, operation of the warranty and could affect your statutory rights.

Control of Substances - Health and Safety Important

This appliance may contain some of the materials that are indicated. It is the Users/Installers responsibility to ensure that the necessary personal protective clothing is worn when handling, where

applicable, the pertinent parts that contain any of the listed materials that could be interpreted as being injurious to health and safety, see below for information.

Firebricks, Fuel beds, Artificial Fuels - when handling use disposable gloves.

Fire Cement - when handling use disposable gloves.

Glues and Sealants - exercise caution - if these are still in liquid form use face mask and disposable gloves.

Glass Yarn, Mineral Wool, Insulation Pads, Ceramic Fibre, Kerosene Oil - may be harmful if inhaled, may be irritating to skin, eyes, nose and throat. When handling avoid inhaling and contact with skin or eyes. Use disposable gloves, face-masks and eye protection. After handling wash hands and other exposed parts. When disposing of the product, reduce dust with water spray, ensure that parts are securely wrapped.

INTRODUCTION

The cooking performance features of the popular and proven solid fuel Rayburn Cookers have been preserved and integrated into the Rayburn 300K and Rayburn 308K burning Commercial Kerosene current issue to BS. 2869 Class C2 suitable for vapourising burners.

The Rayburn 308K provides domestic hot water and cooking facilities, whereas the Rayburn 300K provides cooking facilities only, which consists of a heat-graduated hotplate, main oven and warming oven. The circular oil burner is controlled by a manually operated oil valve control knob. The burner should always be continuously burning at low fire rate when not required for cooking. When cooking is required, the burner operates at a high fire rate by adjustment of the control knob and its setting.

NOTE: For safety and reliability, this appliance must be

commissioned by a competent engineer, such as OFTEC approved.

NOTE: FOR LONG SHUT-DOWN PERIODS, CLOSE ALL OIL VALVES BETWEEN THE OIL TANK AND THE APPLIANCE.

WARNING: OIL BURNER: NEVER ATTEMPT TO RELIGHT A HOT BURNER - DO NOT TURN THE OIL ON UNTIL BURNER IS COOL.

NOTE: SMOKE/SMELL EMITTED DURING INITIAL USAGE

Some parts of the cooker have been coated with a light covering of protective oil. During initial operation of the cooker, this may cause smoke/smell to be emitted and is normal and not a fault with the appliance, it is therefore advisable to open doors and or windows to allow for ventilation. Lift the lids to prevent staining the linings.

WARNING: PLEASE NOTE, DURING USE MANY PARTS OF THE APPLIANCE CAN BECOME HOT TO TOUCH, TAKE CARE IF THE ROOM IS USED BY ELDERLY, INFIRM OR YOUNG PERSONS.

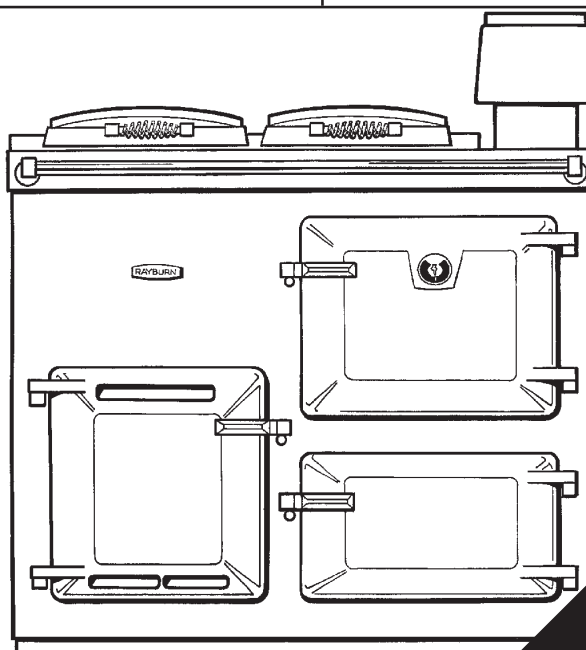

IMPORTANT
 The cooker burner is intended to run in a continuously aight condition at all times, at low fire rate when idling. Turning the cooker burner OFF is NOT recommended unless servicing is required or when the cooker is left unattended for several days.

TO LIGHT THE BURNER - See Fig.1

1. Remove the oil control valve cover, then lift up the reset lever on the front of the oil control valve and turn the cooker oil control valve knob **C** to No. 6 setting. Allow 15 minutes for oil to enter and settle in cooker burner base.
2. Open outer burner door adjacent to the bottom warming oven door, remove/lift out inner burner door.
3. Lift hinged lighting cover on the front of the burner shell and expose the lighting port.
NOTE: TAKE CARE NOT TO DISLodge SHELL FROM ITS SEATING.
4. Insert a taper through the lighting port and light the front wick, then close the lighting cover.
5. Replace inner burner door and close outer burner door.

NOTE: ENSURE INNER COOKER BURNER DOOR IS CORRECTLY LOCATED AND SEALED.

6. Return control knob **C** to its No. 1 setting for about 30 minutes, until the burner is hot, then re-set to No. 6 for cooking.
7. The cooker burner will gradually increase its oil rate, and raise the temperature of the oven, taking about 2 1/2 hours from cold to attain an oven temperature of 200°C (400°F), leaving the cooker control knob **C** at its No. 6 setting. Re-set the cooker control knob **C** at an intermediate setting and the oven temperature will maintain the desired temperature.
8. Set the cooker control knob **C** to No. 1 which is the minimum setting when cooking is not required and idling rate is needed.
9. Ensure both hotplate insulating covers are closed down to conserve heat in hotplate.

To Turn Off Oil Burner

Turn the oil control valve knob **C** from No. 6 setting to 'O' (OFF).

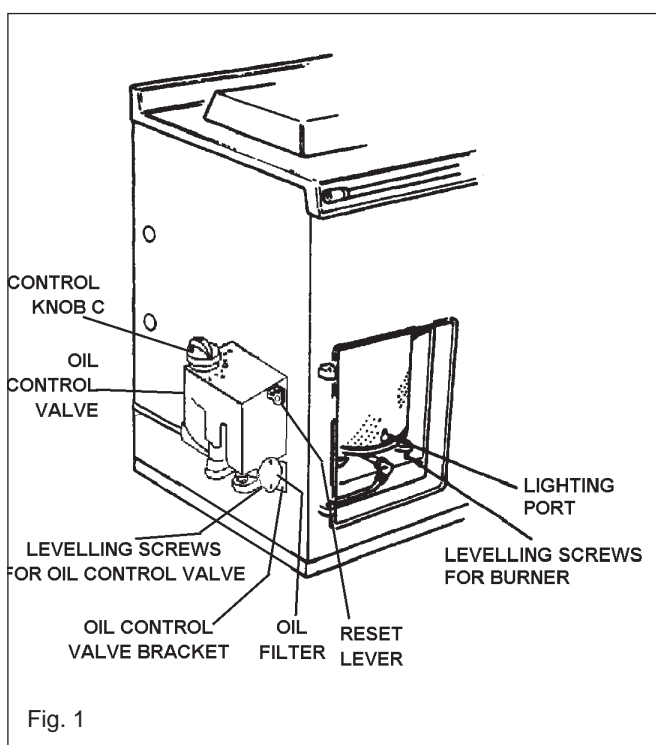

OVEN CONTROL KNOB SETTINGS

The oil control valve **C** is marked 1 to 6 (see Fig. 2), which provides various main oven temperatures with setting 6 being the highest temperature - see chart below.

Cooker Control Knob Setting (308K)	Main Oven Temperature
1	(IDLING) 150° - 170°C
2	170° - 190°C
3	210° - 230°C
4	250° - 270°C
5	HIGH
6	HIGH

NOTE: 300K MODELS MAY OPERATE AT HIGHER TEMPERATURES THAN THOSE QUOTED ABOVE.

To Heat the Top Main Oven and Increase Hotplate Temperature

Turn the control knob **C** to the required setting which will take up to 90 minutes to attain from idling temperatures.

When the top main oven temperature is reached, the required temperature will be maintained by lowering the setting of the cooker control knob.

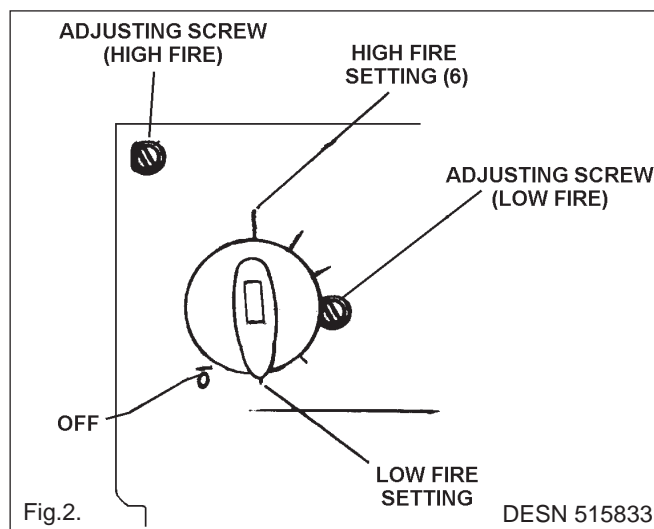

HINT: THE SOLID PLAIN SHELF CAN BE USED AS A HEAT DEFLECTOR, (AS WELL AS A BAKING SHEET). SLIDE ONTO THE RUNNERS TOWARDS THE TOP OF THE OVEN WHICH REDUCES THE HEAT UNDER THE SHELF.

The Hotplate

When the main oven is in use the hotplate will be hot enough for normal needs. The hotplate area above the main oven is used for simmering with the opposite end being the hottest.

At other times, increase the setting of the control knob **C** to increase the temperature of the hotplate.

Pans and kettles must have flat machined bases.

Warming Oven

This is at a low temperature suitable for warming serving plates and dishes. Although not intended as a cooking oven its temperature does vary with the temperature of the main oven.

As a guide, it is around a third the temperature of the main oven.

DOMESTIC HOT WATER - 308K

The supply of domestic hot water to the cylinder is automatic and is at its maximum when the control knob **C** is on No.6 setting, reducing as the control knob setting is reduced. The amount of hot water is increased if a considerable amount of cooking is performed. If more hot water is required overnight, set the control knob **C** to a higher setting than No. 1 (LOW), which is normally sufficient.

OVERNIGHT

Turn the control knob **C** to **No.1** which gives the lowest burning rate and will maintain an oven temperature of about 150°C - 170°C. At a higher setting, the oil consumption will be higher, but the main oven, hotplate and domestic hot water will all be hotter.

Turn up the control knob **C** to No.6 setting in the morning to increase the hotplate temperature and minimise the time to boil a kettle of water.

The recommendations for the best use of the appliance are guidelines only and the respective settings of cooker control knob which suit your requirements will be apparent with experience.

WHEN THE COOKER IS NOT IN USE

During periods of the day when the cooker is not required, the control knob **C** should be set at **LOW** to give the lowest burning rate which will in most cases give sufficient heat to the hotplate and hot water. Use the setting that meets your needs.

Frost Precautions

In the event of the boiler being unheated for long periods during very cold weather, the advice of your installer should be obtained.

COOKING HINTS

DO NOT LEAVE THE ROASTING OVEN DOOR OPEN - If left open for any length of time over-heating may cause damage to some components within the appliance.

The oven is indirectly heated from outside by hot gases from the heat source so that no flame or elements within the oven means full use can be made of the whole cooking space.

The main oven is slightly hotter towards the top than the bottom. At a low idling heat the main oven can be used for long slow cooking such as casseroles, stock, soup, ratatouille, curries, meringues, creme caramels, rice puddings etc., all of which benefit from the gentle slow heat, and as the oven is vented into the flue, cooking smells disappear to the outside.

One of the many benefits of the cast iron main oven is that the floor of the oven is hotter than that of a conventional cooker. No need to bake quiche pastry cases "blind", just place the flan dish on the oven floor for 'soggy-free' pastry. When the oven is hot, the floor of the oven can be used for shallow frying (a cast iron dish is recommended) with the added advantages that fat splashes are carbonised so cleaning is minimised and frying smells are taken away through the flue.

To cook a full load (such as a meal) first pre-heat the oven to setting 4. During cooking, if the temperature on the thermodial starts to drop, it may be necessary to turn the control knob up to a higher setting to maintain the temperature.

If the food begins to over-brown, cover with the solid shelf in the top position.

The top of a hot oven is where grilling takes place. Use the meat tin with a grill rack so that the fat can drip into the tin.

The thermodial temperature gauge, on the main oven door is a guide to the internal oven temperature. Remember though, on opening the door the temperature will appear to drop, do not worry, close the door and after a few minutes the true oven temperature can be read again. Heat is not lost as quickly from a cast iron oven so you can peep at the cake to see how it is cooking without it sinking.

The meat tin supplied with your Rayburn fits the oven size, hanging directly from the runners, so leaving the grid shelves free for other dishes. The oven grid shelves are designed to be non-tilt and should be fitted with the upstand to the top and at the back, so when pulled forward the shelf cannot come right out. (See Fig. 3)

The solid plain shelf, as mentioned before, can be used as a baking sheet or as a heat deflector. If the oven is too hot or food already in the oven is beginning to over-brown, slide the solid plain shelf, above the food. To be effective this shelf should be stored out of the oven, so that it is used from cold.

NOTE: SEE COOK BOOK FOR RECIPES.

DO NOT USE ABRASIVE PADS OR OVEN CLEANERS.

NOTE: IT IS NOT ADVISABLE TO PUT VERY WET CLOTHES ON THE HAND RAIL, AS THIS MAY CRAZE THE ENAMEL.

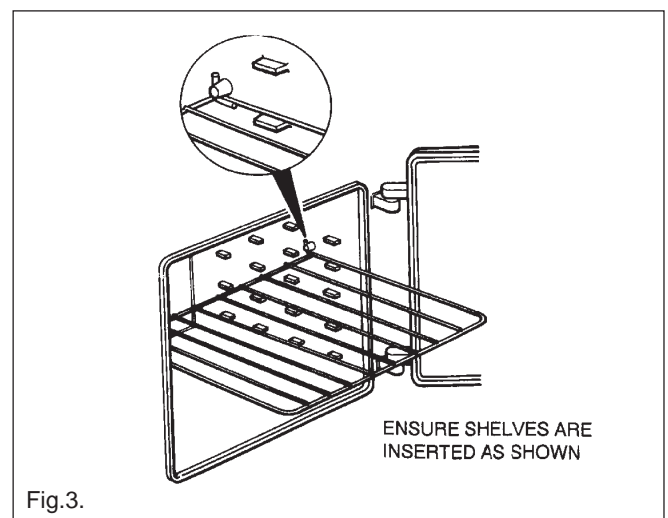

**IMPORTANT - USE COMMERCIAL KEROSENE CURRENT ISSUE TO BS. 2869: CLASS C2 SUITABLE FOR VAPOURISING BURNERS ONLY.
REMEMBER: BE CAREFUL OF THE HOT APPLIANCE**

CLEANING

DO NOT USE A STEAM CLEANER TO CLEAN THIS COOKER

To keep the vitreous enamelled surface bright and clean, wipe over daily with a soapy damp cloth, followed by a clean dry duster. If milk, fruit juice or anything containing acid is spilt on the top plate or down the cooker, be sure to wipe it immediately or the vitreous enamel may be permanently discoloured. Keep a damp cloth handy, while cooking to wipe up spills as they occur, so they do not harden and become more difficult to remove later. If spills do become baked on a cream cleanser can be used. For stubborn deposits a soap impregnated pad can be carefully used on the vitreous enamel.

In the main oven, spills and fat splashes are carbonised at high temperatures; occasionally brush out with a stiff brush. The oven door can be removed for cleaning - do not immerse in water, and shelves can be soaked and cleaned with a cream cleanser.

Both insulating covers should be raised and allowed to cool before cleaning with a soapy damp cloth. Use a wire brush to keep the cast iron hotplate clean.

General cleaning is best carried out when the Rayburn is cool.

IMPORTANT NOTE:

AGA recommend Vitreous Enamel Association approved cleaners for cleaning the vitreous enamelled surfaces of this product.

But they are unsuitable for use on chrome and stainless steel components, including the hand-rails and their brackets.

The insulating covers should be cleaned regularly with a NON-ABRASIVE mild detergent, applied with a soft (coarse free) cloth and lightly polished up afterwards with a soft (coarse free) duster or tissue to bring it back to its original lustre.

BI-ANNUAL SERVICING

Bi-annual Servicing

With normal use a boiler/cooker annual flueway clean and burner maintenance should be carried out at 6 monthly intervals.

The cooker oil valve control knob should be turned OFF by the User the night before the day of the servicing so that the appliance will have cooled down by the following morning.

A HOT APPLIANCE CANNOT BE SERVICED.

Your Rayburn stockist will provide advice on obtaining the nearest selected Servicing Engineer, where we recommend you contract out the periodical servicing of the appliance.

OIL LEAK OR FAULT

If an oil leak or fault exists or is suspected, or if oil fumes are detected around the flue, (this could indicate a flue blockage), then the unit **MUST** be turned off. The appliance **MUST NOT** be used until the fault has been rectified. Advice/Help should be obtained from your qualified Installation/Servicing Engineer.

FUEL

Please endeavour to see that when your fuel is being delivered into your storage tank, that the appliance is left off during delivery, and preferably for a period of 1 hour afterwards to allow sediment within the tank to settle.

Also endeavour to avoid running out of fuel, by seeing that the storage tank is replenished in good time. This will help avoid nuisance breakdowns which can result through fuel starvation.

VENTILATION

Please see that the permanent ventilation provided for the safe and reliable operation of your Rayburn is never blocked off.

**For further advice or information contact
your local distributor/stockist**

With AGA's policy of continuous product improvement, the Company reserves the right to change specifications and make modifications to the appliance described at any time.



from The word "from" is followed by the AGA logo, which consists of the letters "AGA" in a white, bold, sans-serif font inside a dark, rounded rectangular border.

Manufactured by
AGA
Station Road
Ketley Telford
Shropshire TF1 5AQ
England

www.rayburn-web.co.uk
www.agacookshop.co.uk
www.agalinks.com